

# BURLEY®

## Hitch Flex Connector Replacement Instructions For:

Round Tow Bar Kit 950037  
Square Tow Bar Kit 950038

### IMPORTANT

**THIS PART IS DESIGNED FOR USE ON BURLEY TRAILERS ONLY. USE ON ANY OTHER TRAILER CAN RESULT IN SERIOUS INJURY.**

**NOTE:** Your new Burley flex connector should exactly match your old Burley connector.

- **Square tow bar = 4 ridges**
- **Round tow bar = smooth**

These pieces are NOT interchangeable.

### 950037 Contents:

- (1) Hitch connector for round tow bar
- (1) Lock nut
- (1) Safety strap assembly
- (1) Bolt
- (2) D-ring/clip

### 950038 Contents:

- (1) Hitch connector for square tow bar
- (1) Lock nut
- (1) Safety strap assembly
- (1) Bolt
- (2) D-ring/clip

### For use with Burley standard and forged metal hitches

1. Remove trailer from bicycle.
2. Remove existing bolt, safety strap, lock nut and D-ring/clip from flex connector which is located at the end of tow bar. **FIGURE 1**
3. Remove old flex connector from end of tow bar and insert new connector, aligning hole in connector with holes in tow bar.

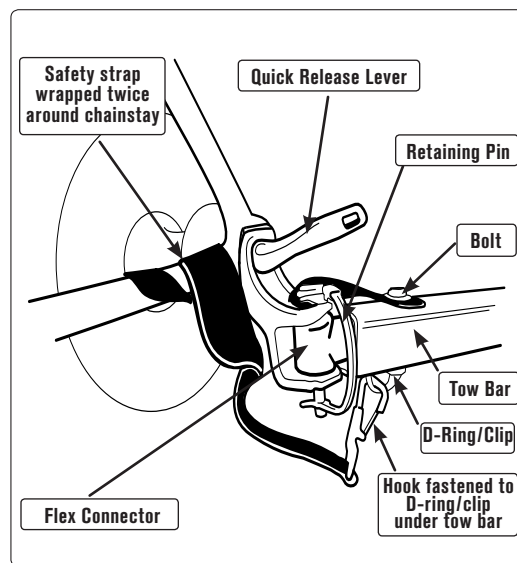

**FIGURE 1:** Forged Hitch Shown

# BURLEY®

## Hitch Flex Connector Replacement Instructions For:

Round Tow Bar Kit 950037  
Square Tow Bar Kit 950038

### IMPORTANT

**THIS PART IS DESIGNED FOR USE ON BURLEY TRAILERS ONLY. USE ON ANY OTHER TRAILER CAN RESULT IN SERIOUS INJURY.**

**NOTE:** Your new Burley flex connector should exactly match your old Burley connector.

- **Square tow bar = 4 ridges**
- **Round tow bar = smooth**

These pieces are NOT interchangeable.

### 950037 Contents:

- (1) Hitch connector for round tow bar
- (1) Lock nut
- (1) Safety strap assembly
- (1) Bolt
- (2) D-ring/clip

### 950038 Contents:

- (1) Hitch connector for square tow bar
- (1) Lock nut
- (1) Safety strap assembly
- (1) Bolt
- (2) D-ring/clip

### For use with Burley standard and forged metal hitches

1. Remove trailer from bicycle.
2. Remove existing bolt, safety strap, lock nut and D-ring/clip from flex connector which is located at the end of tow bar. **FIGURE 1**
3. Remove old flex connector from end of tow bar and insert new connector, aligning hole in connector with holes in tow bar.

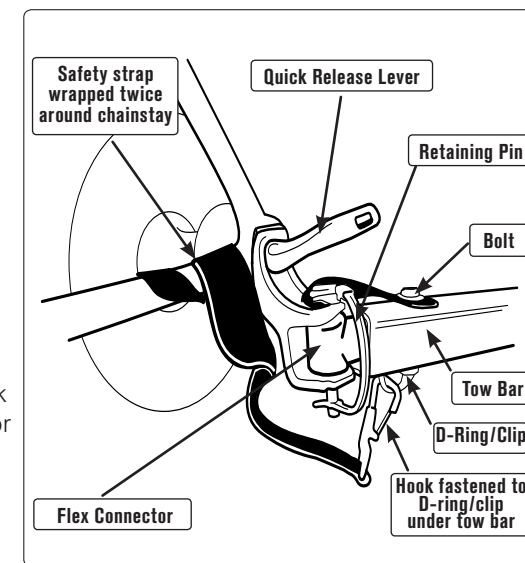

**FIGURE 1:** Forged Hitch Shown

- From above, insert new bolt through safety strap grommet, tow bar, and D-ring/clip, and securely tighten new lock nut. (Lock nut (NOT SHOWN) is located directly underneath tow bar where bolt is inserted from the top of tow bar.) **FIGURE 1**
- To hitch to the bicycle, insert retaining pin from above through hitch and flex connector holes. Close retaining pin.
- Wrap safety strap around inside of bicycles chain stay twice, and fasten hook to D-ring/clip on tow bar.

## For use with Burley Classic (Plastic) Hitch

**NOTE:** The safety strap included in this kit has a retaining pin, which works with Burley metal hitches. The Classic hitch uses a bolt/nut in place of the retaining pin. A replacement safety strap for the Classic Hitch (Kit # 950067), with the bolt/nut, is available for purchase from your Authorized Burley Dealer or [www.burley.com](http://www.burley.com).

- To remove trailer from bicycle hitch:
  - Unfasten hook on safety strap from D-ring on tow bar. **FIGURE 2**
  - Remove shoulder bolt, lock nut and washer from flex connector in end of tow bar, and disconnect trailer tow bar from hitch. **FIGURE 2**
- Remove bolt, safety strap, lock nut and D-ring/clip from tow bar.
- Replace old flex connector with new connector, aligning hole in connector with hole in tow bar.
- From above, re-install bolt through tow bar, safety strap grommet and D-ring/clip, and securely tighten lock nut.
- To connect tow bar to Classic Hitch, slide new flex connector between hitch arms and line up holes.
- From below, insert shoulder bolt through inner grommet on safety strap, flex connector and hitch arms. Install lock nut and tighten securely.
- Wrap safety strap around inside of chain stay twice, and fasten hook to D-ring on tow bar.

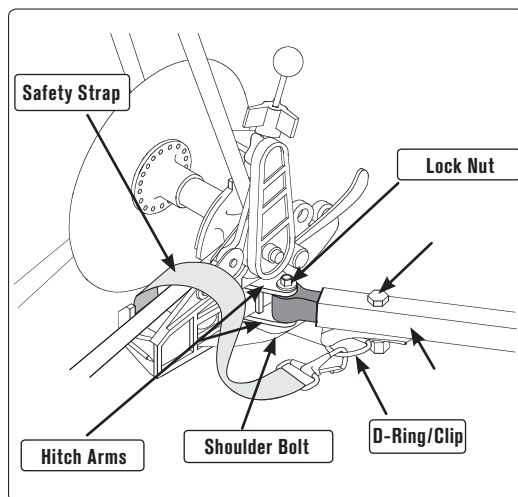

**FIGURE 2:** Classic Hitch

**BURLEY DESIGN**

Copyright © 2008 by Burley Design LLC. "Burley" is a registered trademark of Burley Design LLC : Rev 07/08 : 170137 Hitch Flex Connector Replacement Instructions r0  
4020 Stewart Rd. Eugene, OR 97402 : PH 541.687.1644 800.423.8445  
FAX 541.687.0436 : [burley@burley.com](mailto:burley@burley.com) : [www.burley.com](http://www.burley.com)

- From above, insert new bolt through safety strap grommet, tow bar, and D-ring/clip, and securely tighten new lock nut. (Lock nut (NOT SHOWN) is located directly underneath tow bar where bolt is inserted from the top of tow bar.) **FIGURE 1**
- To hitch to the bicycle, insert retaining pin from above through hitch and flex connector holes. Close retaining pin.
- Wrap safety strap around inside of bicycles chain stay twice, and fasten hook to D-ring/clip on tow bar.

## For use with Burley Classic (Plastic) Hitch

**NOTE:** The safety strap included in this kit has a retaining pin, which works with Burley metal hitches. The Classic hitch uses a bolt/nut in place of the retaining pin. A replacement safety strap for the Classic Hitch (Kit # 950067), with the bolt/nut, is available for purchase from your Authorized Burley Dealer or [www.burley.com](http://www.burley.com).

- To remove trailer from bicycle hitch:
  - Unfasten hook on safety strap from D-ring on tow bar. **FIGURE 2**
  - Remove shoulder bolt, lock nut and washer from flex connector in end of tow bar, and disconnect trailer tow bar from hitch. **FIGURE 2**
- Remove bolt, safety strap, lock nut and D-ring/clip from tow bar.
- Replace old flex connector with new connector, aligning hole in connector with hole in tow bar.
- From above, re-install bolt through tow bar, safety strap grommet and D-ring/clip, and securely tighten lock nut.
- To connect tow bar to Classic Hitch, slide new flex connector between hitch arms and line up holes.
- From below, insert shoulder bolt through inner grommet on safety strap, flex connector and hitch arms. Install lock nut and tighten securely.
- Wrap safety strap around inside of chain stay twice, and fasten hook to D-ring on tow bar.

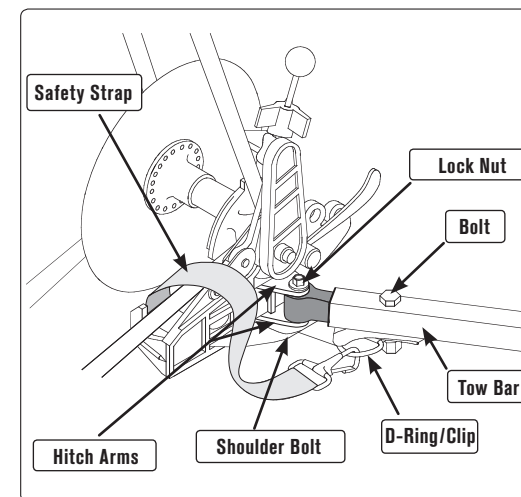

**FIGURE 2:** Classic Hitch

**BURLEY DESIGN**

Copyright © 2008 by Burley Design LLC. "Burley" is a registered trademark of Burley Design LLC : Rev 07/08 : 170137 Hitch Flex Connector Replacement Instructions r0  
4020 Stewart Rd. Eugene, OR 97402 : PH 541.687.1644 800.423.8445  
FAX 541.687.0436 : [burley@burley.com](mailto:burley@burley.com) : [www.burley.com](http://www.burley.com)